

MEKA

TRACK MOUNTED JAW CRUSHER MEKATRACK MTJ1165

Perfect design,
high quality of material,
more throughput,
more profitability.





MEKA

MTJ1165 TRACK MOUNTED JAW CRUSHER

MEKA J Series mobile jaw crushers provide true mobility with compact dimensions. MEKATRACK MTJ1165 is easy to transport between sites, provides fast set-up time and low operational costs with an excellent crushing capacity.

Temporary aggregate production is common for short-term projects like road and dam construction. Since most of the time the equipment is moved out of the temporary quarry, disassembly, transportation and installation expenses add extra costs that can be just as significant as the start-up investment itself. In such cases, despite higher initial investment costs, mobile crushing and screening solutions are better options than stationary ones because of the time-saving disassembly, transportation and installation advantages they provide.

For use in

- Natural Stone
- Recycling
- Mining



MEKA

WHY MEKA J SERIES MOBILE JAW CRUSHERS?

- True mobility with compact dimensions
- Easy to transport between sites
- Fast set-up time and low operational costs
- Built around the high performance MEKA-J1165 jaw crusher
- Excellent crushing capacity
- Single unit for hard rock and recycle materials
- Built with proven components
- Unbeatable recycling versatility
- Advanced user friendliness and safety
- Safe and reliable process with easy control system
- High efficiency power package to ensure maximum productivity
- Environmentally friendly diesel motor
- Unmatched reliability provides maximum machine availability as the start-up investment itself. In such cases, despite higher initial investment costs, mobile crushing and screening solutions are better options than stationary ones because of the time-saving disassembly, transportation and installation advantages they provide.

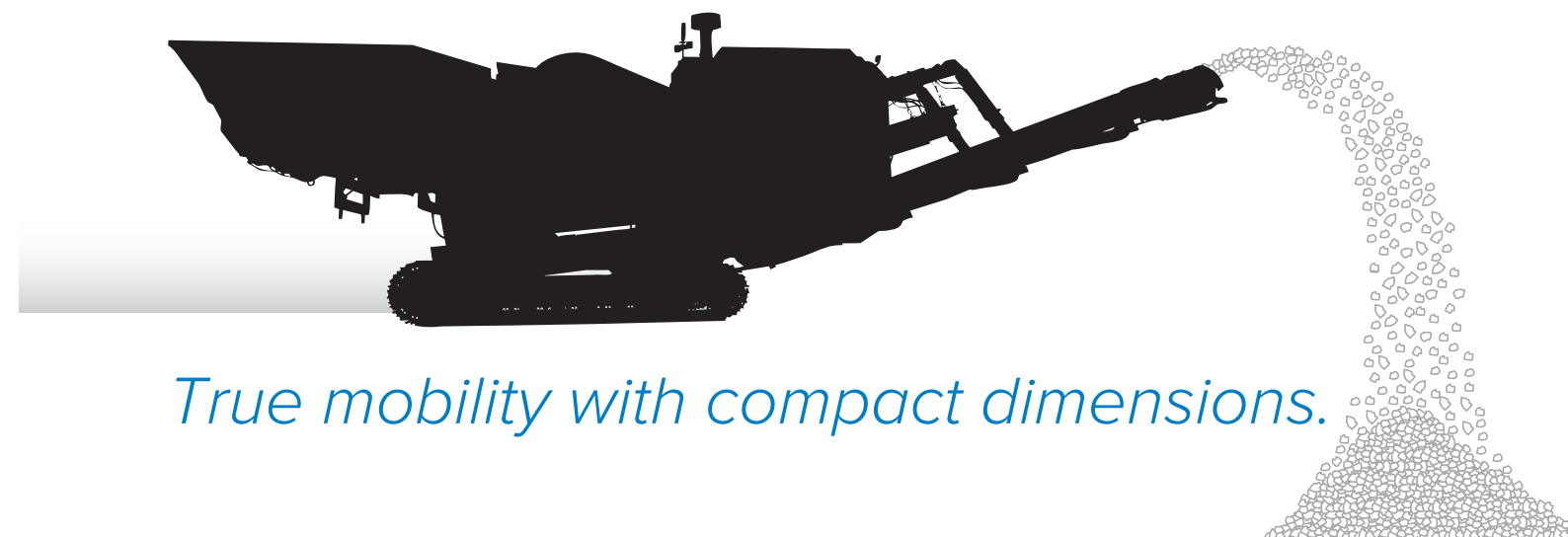

True mobility with compact dimensions.

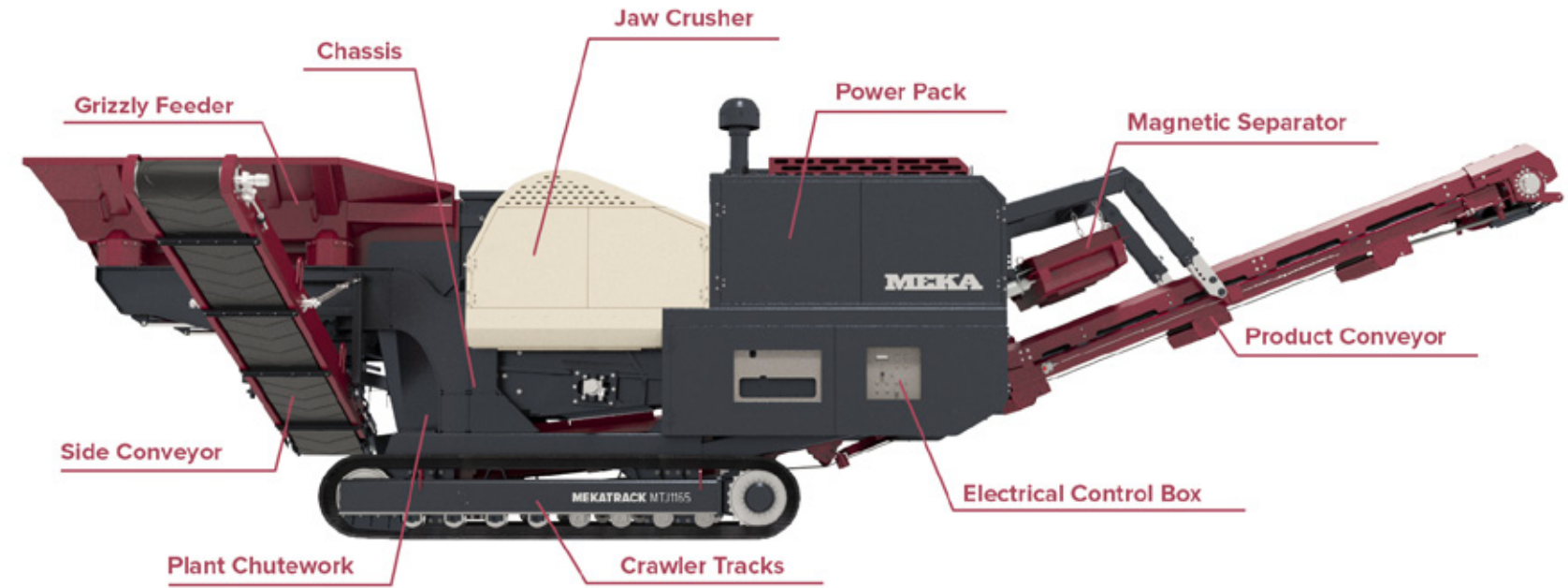

Remote Control

Will control the tracking function and also provides stop and start controls for the grizzly feeder.

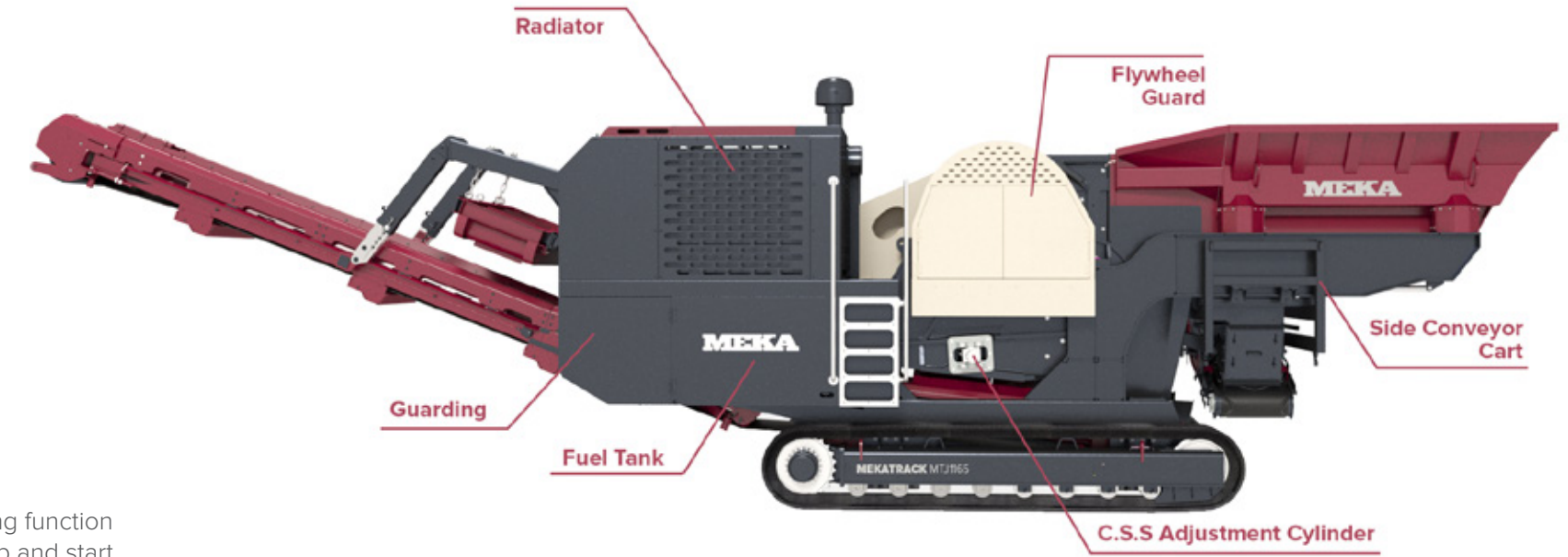

Crusher Feed Chute

One piece fabrication with 25 mm thick on the side and 20mm thick on the top and bottom parts with wear resistant steel plate.

Grizzly Fines/Bypass Chute

A two-way dirt chute is provided to discharge to the product conveyor or the dirt conveyor. Fabricated in 6mm mild steel plate, complete with flap door to direct grizzly fines to either the side dirt conveyor or the main product conveyor.

Powerpack

- Type** : CAT™ C9.3 ACERT™
- Performance** : 242 kW (325 HP) at 1700 rpm at sea level
- Fuel tank capacity** : 450 Litres nominal
- Fuel consumption** : 30-35 lt/hr
- Clutch type** : Highly efficient, self-adjusting coupling with gearbox
- Drive** : Direct drive hydraulic pumps
- Access** : Easy Access canopy for all engine services

Guarding

- Sheet metal guards are provided for all drives, flywheels, pulleys and couplings.
- The guards provided are designed and manufactured to meet CE standards.
- Hinged access guards are provided on the top, side ends of the engine, flywheels, hydraulic equipment and control panel.

Platforms and Ladder

A detachable access ladder with double row handrails is provided to gain access to the powerpack and the crusher. A platform with special grating is also included to gain access to the crusher and the powerpack.

Chassis

Heavy-duty fabricated I section of welded construction. (Stress relieved with heat treatment)

POWERFUL FEEDING UNIT WITH BYPASS CHUTE OPTIONS



GRIZZLY FEEDER

Type	: Spring mounted vibrating pan and grizzly
Hopper volume	: 4.2 – 4.5 m ³
Hopper width	: 2550 mm
Feeder width	: 1046 mm
Feeder length	: 4070mm
Maximum feed size	: 520 mm
Vibrating Unit	: Twin heavy-duty cast eccentric shafts running in spherical roller bearings, gear coupled at drive end
Drive	: Flange mounted hydraulic motor
Grizzly	: Two replaceable 1760mm long stepped grizzlies with nominal 60mm aperture tapered from front to back.
Operating principle	: With hydraulic motor, operating speed can be adjusted from the control panel (maximum 1100 rpm)

Crusher Feed Chute

One piece fabrication with 25 mm thick on the side and 20mm thick on the top and bottom parts with wear resistant steel plate.

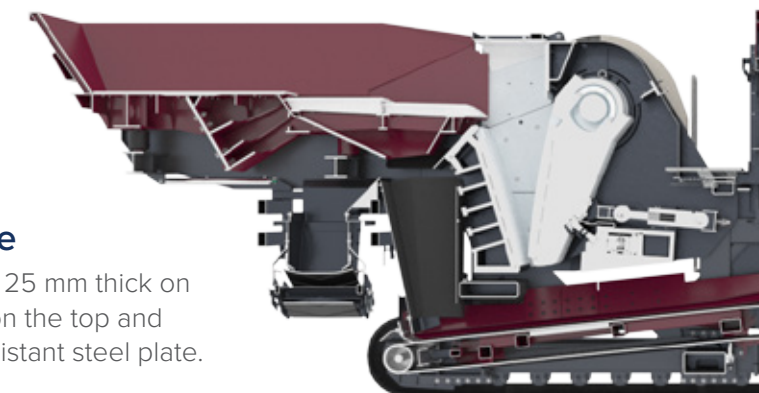

Grizzly Fines/Bypass Chute

A two-way dirt chute is provided to discharge to the product conveyor or the dirt conveyor. Fabricated in 6mm mild steel plate, complete with flap door to direct grizzly fines to either the side dirt conveyor or the main product conveyor.

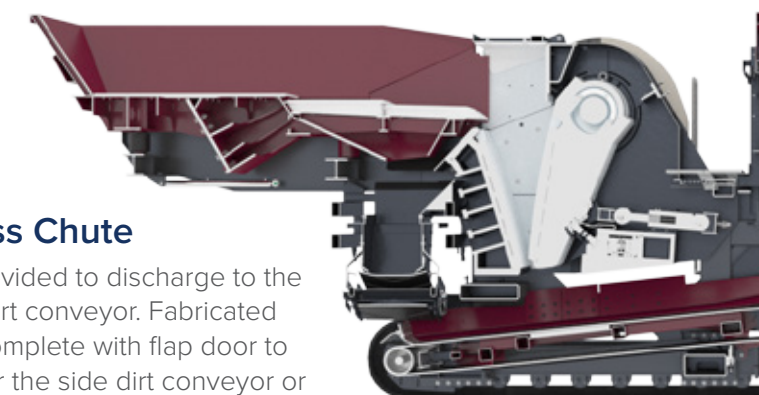

MEKA

WITH THEIR EXCELLENT ENGINEERING AND HIGH-QUALITY MANUFACTURING / J1165

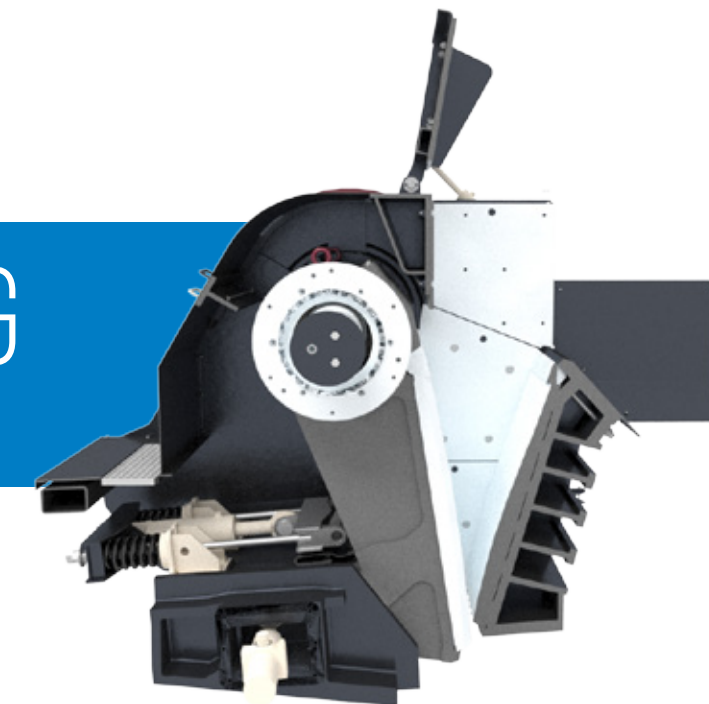
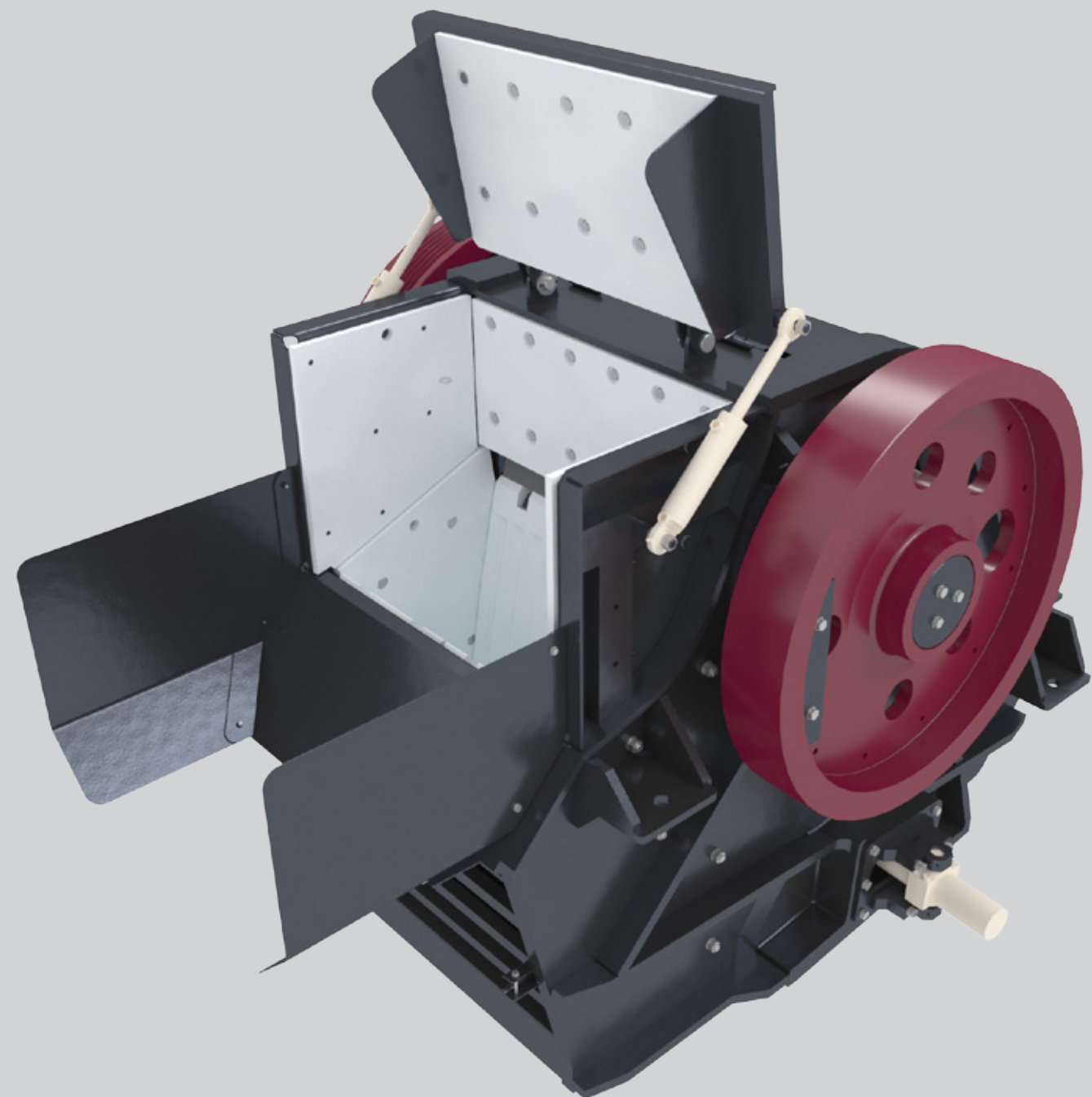

JAW CRUSHER

Model: MEKA-J1165

Crusher type	: Single toggle with hydraulic setting adjustment system
Feed opening	: 1100x650 mm
Drive	: V-Belt, flywheel and hydraulic motor
Crusher rotation	: Reversible(clockwise/anticlockwise)
Normal operation	: Anticlockwise
Closed side setting	: 60mm standard, can be adjusted between 55-150mm
Speed	: 190-220 rpm
Bearings	: Self aligning spherical roller type
Spring adjustment	: With hydraulic cylinders
Lubrication	: Grease, manually (Optional automatic lubrication)

Features of J1165/Jaw Crusher

- Quick and easy setting adjustment,
- Fixed and swing jaws are common and can be changed rapidly
- Strong frame construction with no welding in critical areas, heat treatment after welding
- Eccentric shaft arrangement for lower stresses
- Cartridge type bearing arrangement
- Improved manganese liner retention
- Side plates: Wear resistant steel
- Reversible operation is possible incase of blockage
- Improved design and upward positioning of the toggle plate, provides a more aggressive crushing action compared to regular jaw crushers. Material fed to the upper section of the crushing chamber is forced to the lower section of the chamber and the quad motion at the discharge end pushes the crushed material upwards back into the crushing chamber. The material will be crushed again and will result in production of cubical products.



MEKA

ROBUST AND TOP QUALITY DISCHARGE CONVEYOR AND MAGNETIC SEPERATOR

PRODUCT CONVEYOR

Design : Conveyor is designed to be lowered for the removal of trapped material and for transportation. The conveyor can be lowered and raised when crushing. Fully removable modular unit to aid access and maintenance.

Belt type : EP 500/3 ,with 10mm top and 3mm bottom heavy duty rubber covers with steel reinforcement and with vulcanised joint.

Belt width : 1200 mm

Belt length : 12000 mm

Maximum discharge height
3950 mm (Adjustable with hydraulic mechanism)

Maximum clearance
510 mm (Jaw to belt when lowered)

Drive : Direct drive hydraulic motor

Belt adjustment : Belt tensioning by screw at the drive and tail drum

Belt Scraper : Polyurethane and Polyethelene blades

Lubrication : Manual grease lubrication for the drum bearings

Skirting : Wear resistant rubber sealing skirts along the entire conveyor length

ON PLANT SIDE/DIRT CONVEYOR

Belt type : EP 400/3 ,with 10mm top and 4mm bottom heavy duty rubber covers with vulcanised joint.

Belt width : 650 mm

Belt length : 6000 mm

Discharge height : 3110 mm

Drive : Direct drive hydraulic motor

Belt adjustment : Belt tensioning by screw at the drive and tail drum

Belt Scraper : Polyurethane and Polyethelene blades

Lubrication : Manual grease lubrication for the drum bearings

Skirting : Wear resistant rubber sealing skirts along the entire conveyor length Can be positioned on the right or left side of the unit

MAGNETIC SEPARATOR

Type : Suspended self-cleaning overband

Magnet Width : 550 mm

Magnet Length : 1268 mm

Drive : Hydraulic motor

Control : Pre-set variable speed

Discharge Chute : Via stainless steel shedder plate

Magnetic strength : 450 Gauss at 250mm

MEKA

EASY TRANSPORT AND TRUE MOBILITY WITH CRAWLER TRACKS



CRAWLER TRACKS

Type	: Heavy-duty tracks fitted as standard
Pitch	: 171.5 mm
Longitudinal centers	: 3800 mm
Track width	: 500 mm
Climbing grade	: 27.4° maximum
High speed	: 1,2 km/hr
Slow speed	: 0.6 km/hr
Drive	: Hydraulic integral motors
Track tensioning	: Hydraulic adjuster, grease tension

Mekatrack is immediately ready for work on the mining, quarrying and recycling industries, especially those working in urban locations or where space is restricted.